

ARZOPA

# A1 GAMUT

15.6" Portable Monitor

**USER GUIDE**

[www.arzopa.com](http://www.arzopa.com)

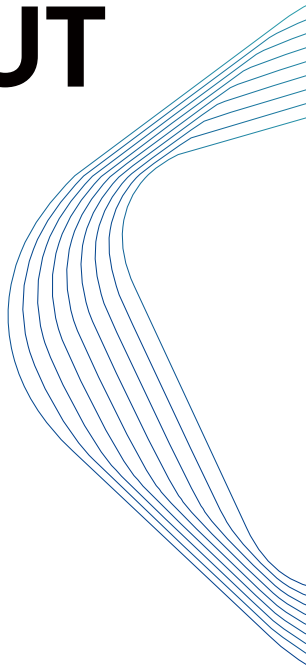



# Tech Support

If you have any problems with the monitor, please free to contact us for quick response and professional techs support.



Official Website



Facebook



Official Website  
[www.arzopa.com](http://www.arzopa.com)



Facebook  
[@Arzopatech](https://www.facebook.com/Arzopatech)



Tech Support  
[support@arzopa.com](mailto:support@arzopa.com)  
24/7 service



[@arzopa](https://twitter.com/arzopa)

# Contents

Package List	1
Monitor Introduction	2
Connect Monitor with Devices	3
Duplicate & Extend Mode Setting	7
Screen Rotate Setting	8
OSD Function Introduction	9
Set Up The Smart Cover	13
Specifications	14
Supported Devices & Models	15
Common Problems and Solutions	17
Notices	18

# Package List



Monitor x1

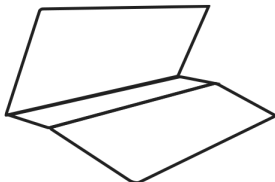

Smart Cover x1

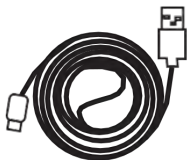

Type-C to USB-A  
Cable x1



Type-C to Type-C  
Cable x1



Mini HDMI to HDMI  
Cable x1



Charger x1

# Monitor Introduction

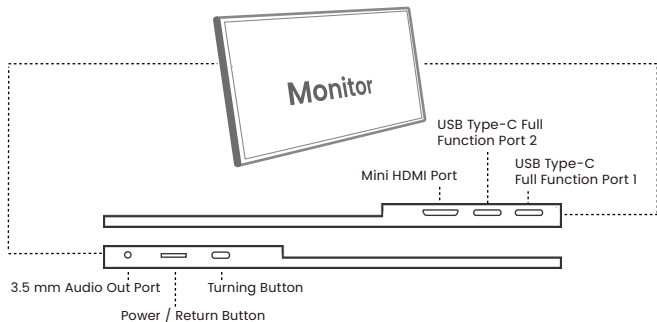

**Mini HDMI Port :** Receive audio/video signals.

**USB Type-C Function Port1/Port2 :** USB C 3.1 support reversible insertion and reverse charging.

Compatible with USB PD2.0 power supply,supports 5V /9V /12V /15V /20V input .

**Power/Return Button :** Press and hold ~3 seconds to turn on/off the monitor.

**Turning Button :**

- OSD Menu: Press to enter OSD menu.
- UP/DOWN turning switch: When in a menu, press Turning Button to select menu item.
- Brightness/Volume Adjustment: When not on a menu, push the Turning Button UP once for the Brightness quick-access. Or push the Turning Button DOWN once for the Volume quick-access.

**3.5 mm Audio Out Port :**

To connect to 3.5 mm-compatible external audio device.

# Connect Monitor with Devices

## 1. Connection Condition

This monitor does not have a built-in battery. Before connecting the monitor, Please make sure there is enough power(5V/3A OR ABOVE) input.

## 2. LAPTOP (With Type-C)

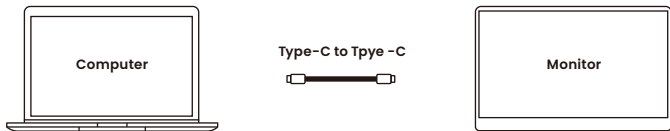

**Note:** If you want to adjust the brightness and volume above 80%, please make sure the external power supply of 5V/3A or above be connected.

**Note:** Not all laptops with a Type-C port can work with ARZOPA monitor. Please check the Type-C port of your laptop if it supports audio and video signal transmission.

### 3. PC / Laptop (With HDMI Port)

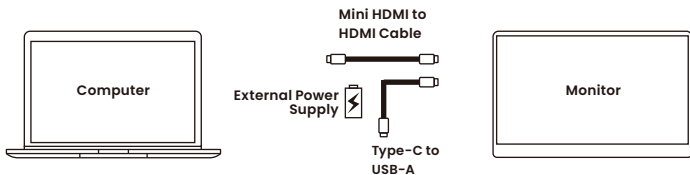

OR

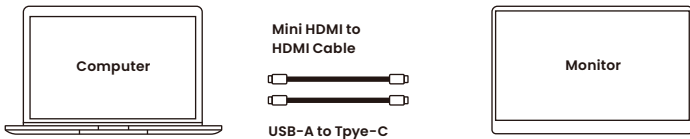

**Note:** HDMI port does not support power transmission. So when you use HDMI connection, you must connect extra power supply (5V/3A or above).

## 4. PHONE (With Tpye-C)

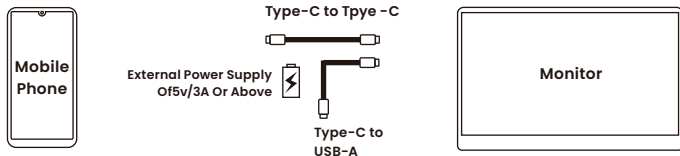

When there is no external power supply, the cell phone will supply power to the monitor.

(Energy-saving mode is activated, brightness will be automatically adjusted to 15%.)

When the external power supply is connected, the cell phone will also be charged through the external power supply.

(To ensure the monitor and the phone can get enough working current, please use at least 15W charger or power bank as the external power supply.)

**Note:** Only works directly with cell phone through full-featured Type-C port.

**For iPhone:** need a lightning to HDMI adaptor.

## 5. Other Devices

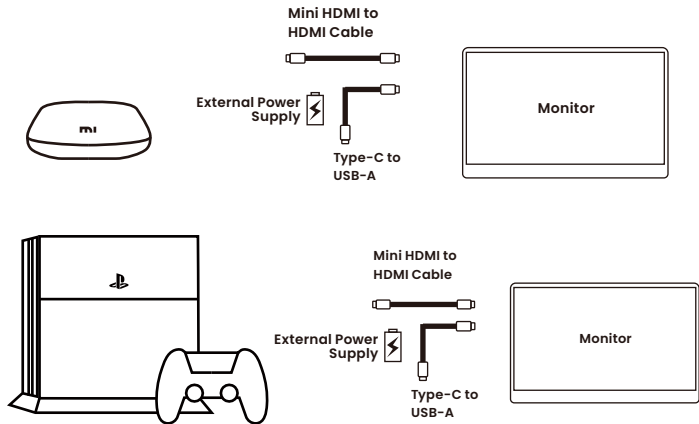

**Note:** Please connect the power supply cable first and then Mini HDMI to HDMI Cable to ensure the smooth transmission of signals. When connecting the Nintendo Switch, 30W or above is required for the power adapte.

# Duplicate & Extend Mode Setting

1. Connect your ARZOPA monitor to a power outlet and an available port on your PC.
2. Right-click the desktop and select either screen resolution (Window 7/8) or display settings (Window 10).
3. Click the multiple displays drop-down list, and then select extend these displays, note if you cannot see the additional monitor(s) listed, click detect. If does not work, try restarting your computer and do steps again.

## Change the appearance of your displays

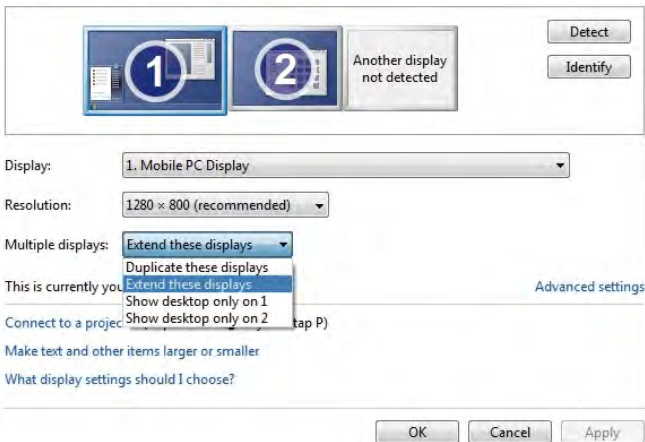

The screenshot shows the Windows Display Settings dialog box. At the top, there are three display icons: a blue monitor labeled '1', a dark blue monitor labeled '2', and a grey monitor labeled 'Another display not detected'. To the right of these icons are 'Detect' and 'Identify' buttons. Below the icons, the 'Display:' dropdown is set to '1. Mobile PC Display'. The 'Resolution:' dropdown is set to '1280 x 800 (recommended)'. The 'Multiple displays:' dropdown is open, showing options: 'Extend these displays' (highlighted), 'Duplicate these displays', 'Extend these displays', 'Show desktop only on 1', and 'Show desktop only on 2'. To the right of the dropdown is a link for 'Advanced settings'. At the bottom of the dialog are 'OK', 'Cancel', and 'Apply' buttons.

# Screen Rotate Setting

1. Connect your ARZOPA monitor to a power outlet and an available port on your PC.
2. Right-click the desktop and select either screen resolution (Windows 7/8) or display setting (Windows 10).
3. Click the orientation drop-down list, and then select Landscape or portrait screen.

**Note:** If you cannot see the option of orientation on your laptop/PC, please check if your laptop/PC has this function.

Screen Resolution

< Appearance and Personalisation > Display > Screen Resolution

Search Control Panel

Change the appearance of your displays

Detect

Identify

Display: 1. ThinkPad Display 1366x768

Resolution: 768 x 1366 (Recommended)

Orientation: Portrait

Multiple displays: Portrait

Make this my main display

[Advanced settings](#)

[Project to a second screen \(or press the Windows logo key + P\)](#)

[Make text and other items larger or smaller](#)

[What display settings should I choose?](#)

OK Cancel Apply

# OSD Function Introduction

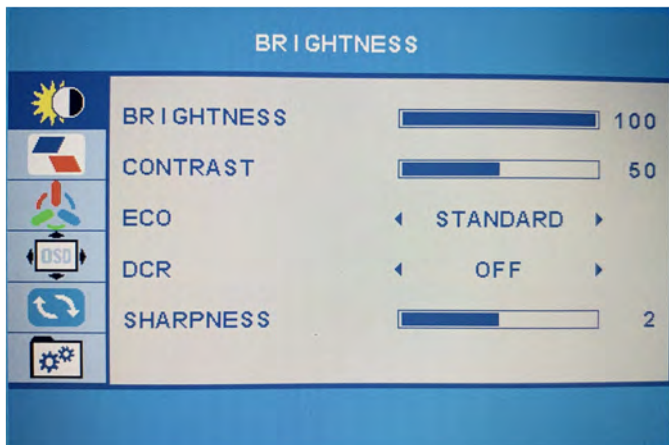

1. Press the turning button to activate the OSD menu.
2. Scroll the turning button up and down to choose your settings.
3. Press turning button to confirm.
4. Press Power Button to return to the previous previous page.

<b>Brightness</b>	<b>Brightness</b>	The adjusting range is from 0 to 100.
	<b>Contrast</b>	The adjusting range is from 0 to 100.
	<b>ECO</b>	Contains seven modes(Standard/ Game/Movie/Text/FPS/RTS/ECM Modes).
	<b>DCR</b>	Select ON or OFF to enable or disable dynamic contrast ratio function.
	<b>Sharpness</b>	The adjusting range is from 0 to 100.
<b>Image</b>	<b>Aspect</b>	Adjusts the aspect ratio to 4:3/WIDE.
<b>Color Temp</b>	<b>Color Temp</b>	Contains three preset color modes (Standard,Cool, Warm) and User Mode.
	<b>Red</b>	The adjusting range is from 0 to 100.

<b>Color Temp</b>	<b>Green</b>	The adjusting range is from 0 to 100.
	<b>Blue</b>	The adjusting range is from 0 to 100.
<b>OSD Setting</b>	<b>Language</b>	Select OSD language. The selections are: English, French, German, Simplified Chinese, Italian, Spanish, Portuguese, Turkish, Polish, Nederlands, Japanese, Korean.
	<b>OSD H. POS.</b>	The adjusting range is from 0 to 100.
	<b>OSD V. POS.</b>	The adjusting range is from 0 to 100.
	<b>OSD Timer</b>	The adjusting range is from 10 to 60.
	<b>Transparency</b>	The adjusting range is from 0 to 100.

<b>Reset</b>	<b>Reset</b>	Selects RESET to revert all settings to the factory default mode.
	<b>Auto powerdown</b>	Select the time for the monitor to turn off automatically. (10/20/30/40/50/60/120/240 min)
	<b>HDR MODE</b>	Select ON or OFF to open HDR mode.
<b>Misc.</b>	<b>Signal Source</b>	Contains two signal sources Type-C and HDMI.
	<b>Low Blue Light</b>	The adjusting range is from 0 to 100. (0/25/50/75/100)
	<b>Volume</b>	The adjusting range is from 0 to 100.

# Set Up The Smart Cover

You can stand up the monitor by different positions with the smart cover.

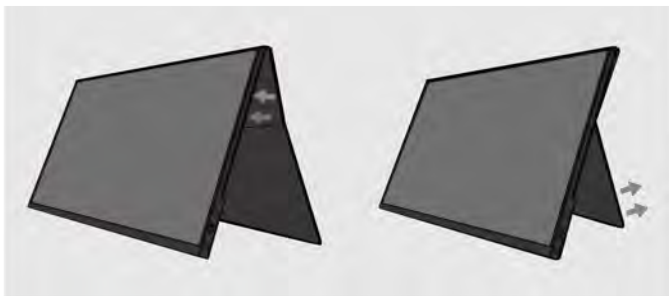
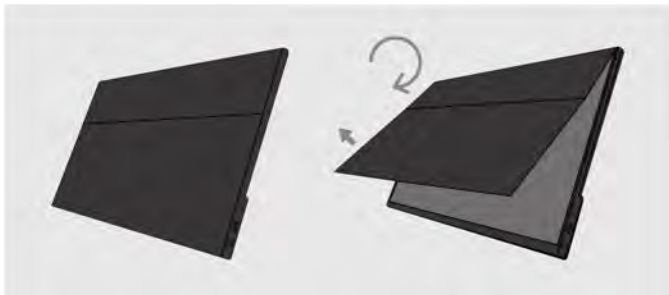

# Specifications

**Product Name:** ARZOPA Type-C Portable Monitor

**Screen Size:** 15.6 Inch

**Panel Type:** IPS

**Aspect Ratio:** 16:9

**Resolution:** 1920\*1080

**Display Color:** 16.7M

**Color Temperature:** 6800K

**Visual Angle:** H: 85°/85°Min V: 85°/85°Min

**Contrast Ratio:** 1000:1

**Brightness:** 300cd/m<sup>2</sup>

**Color Gamut:** 72%

**Input Interface:** Mini HD(Video Signal),

Type-C Full Function(Video Data, Power Supply ISDN),

**Output Interface:** 3.5mm Headphone Interface

**Speaker:** Built-in Speakers(1W\*2)

**Refresh Rate:** 60Hz

**\*Specifications are subject to change without notice.**

# Supported Devices & Models

## 1. Phone

<b>Brand</b>	<b>Model</b>
<b>HUAWEI</b>	P20 / P20 RS / P20 Pro / P30 / P30 Pro / Mate 10 / 10 Pro 20 / 20 X / 20 Pro / 30 / 30 Pro / RS
<b>SAMSUNG</b>	S8 / S8+ / S9 / S9+ / S10 / S10+ / S20 / Note 8 Note 9 / Note 10 / Note 10+ (Connecting Samsung need extra power supply)
<b>Razer</b>	Razer Phone / Razer Phone 2
<b>OnePlus</b>	OnePlus 7 / OnePlus 7 Pro / OnePlus 7T
<b>Sony</b>	Xperia 1 / Xperia 5 / Xperia XZ3
<b>NOKIA</b>	NOKIA 9 Pure / View. ASUS: ROG / ROG2
<b>HONOR</b>	Note 10, V20 /30
<b>HTC</b>	U Ultra
<b>OPPO</b>	R17 Pro /Reno /Find. LG: G5 /G6 /G7
<b>More</b>	To be updated

## 2. Laptop

<b>Brand</b>	<b>Model</b>
<b>Apple</b>	MacBook 12in /2016 /2017 Pro MacBook Air 2018 iPad Pro 2018-2020
<b>HUAWEI</b>	MateBook D / MateBook E / MateBook X MateBook X Pro / MateBook 13/MateBook 14 /MagicBook
<b>Microsoft</b>	SurfaceGo / Surface Book 2
<b>ASUS</b>	ZenBook 3 / ZenBook 3 Pro / ZenBook X / U4100 U4100UN / AU5100UQ /G3 /G5 /G7 /Inspiron 5000 Inspiron 7000 / XPS13 /XPS15
<b>MI</b>	Mi Air 12.5 / Air 13.3 / Pro 15.6 / Pro 15.6 GTX
<b>Lenovo</b>	Y7000 / Y7000P / Y900K / YOGA 6 PRO ThinkPad X1 / Carbon / MIIX 720 /Yoga 5 Pro
<b>DELL</b>	G3 / G5 / G7 / Inspiron 5000 / Inspiron 7000 / XPS13 XPS15 / Latitude 5285 /Latitude 3520
<b>Google</b>	Pixelbook /PielBook Pen
<b>Razer</b>	Blade Stealth / Blade Pro
<b>Nvidia</b>	Geforce RTX 2070 / Geforce RTX 2080 Geforce RTX 2080Ti
<b>More</b>	To be updated. Compatible with most PCs or Laptops.

# Common Problems and Solutions

## **Q1: Shows "no signal" after a certain period of time.**

1. Check if the wires are loose, re-plug them and make sure they are connected correctly.
2. Replace the cable with a new one and see if the same thing happens.
3. If you have tried all of the above and the problem is not resolved, please contact our after-sales email.

## **Q2: Why do I have to plug in two cords if I don't have a USB-C port on my laptop?**

A: The USB-C to USB-C cord is strong enough to communicate power and transmission signal through one cord . If you can't use the USB-C to USB-C cord, it must to use the HDMI cord along with the USB-A to USB-C cord, one for transmission and one for power.

## **Q3: My monitor won't power on.**

A: If you are not using a USB-C cord , make sure your monitor is connected to your laptop with both the HDMI cord and the USB-A to USB-C. Then, press and hold the on/off button to power up the monitor.

## **Q4: The screen flicker black when displaying content.**

A: Please check if the connection is loose, if there is no problem with the connection, it may be due to insufficient power supply, please connect the adapter and use it again, or replace the power adapter or data cable with a new one.

# Notices

- Before setting up this Type-C Portable Display, carefully read all the documentation that came with the package.
- To prevent fire or shock hazard, never expose this Type-C Portable Display to rain or moisture.
- Never try to open this Type-C Portable Display cabinet.
- Before using this Type-C Portable Display, make sure all cables are correctly connected and the power cables are not damaged.
- Avoid dust, humidity, temperature extremes and bumpy places.
- Never push objects or spill liquid of any kind into the slots on this Type-C Portable Display cabinet.
- If you encounter technical problems with this Type-C Portable Display, contact our tech support ([support@arzopa.com](mailto:support@arzopa.com)) immediately.





ARZOPA

 E-mail: [support@arzopa.com](mailto:support@arzopa.com)